



UNIVERSITEIT  
iYUNIVESITHI  
STELLENBOSCH  
UNIVERSITY

100  
1918 · 2018



**WMT**  
Mess- und Prüftechnik

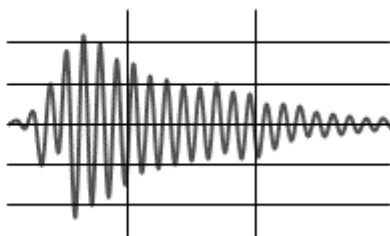

# Investigation of fan vibration

Jacques Muiyser<sup>1</sup>, Frank Weissbuch<sup>2</sup>, Trung Luu<sup>3</sup>, Pascal Malpoix<sup>3</sup>  
and Hanno Reuter<sup>1,3</sup>

<sup>1</sup> Department of Mechanical and Mechatronic Engineering, Stellenbosch University

<sup>2</sup> WMT Mess- und Prüftechnik

<sup>3</sup> Hamon Thermal Europe S.A.



# Introduction

## ACC:

25 fan cells per block  
36 foot diameter

## Our objective:

Investigate recurring trips  
due to vibration levels exceeding the values  
specified in ISO 10816-3

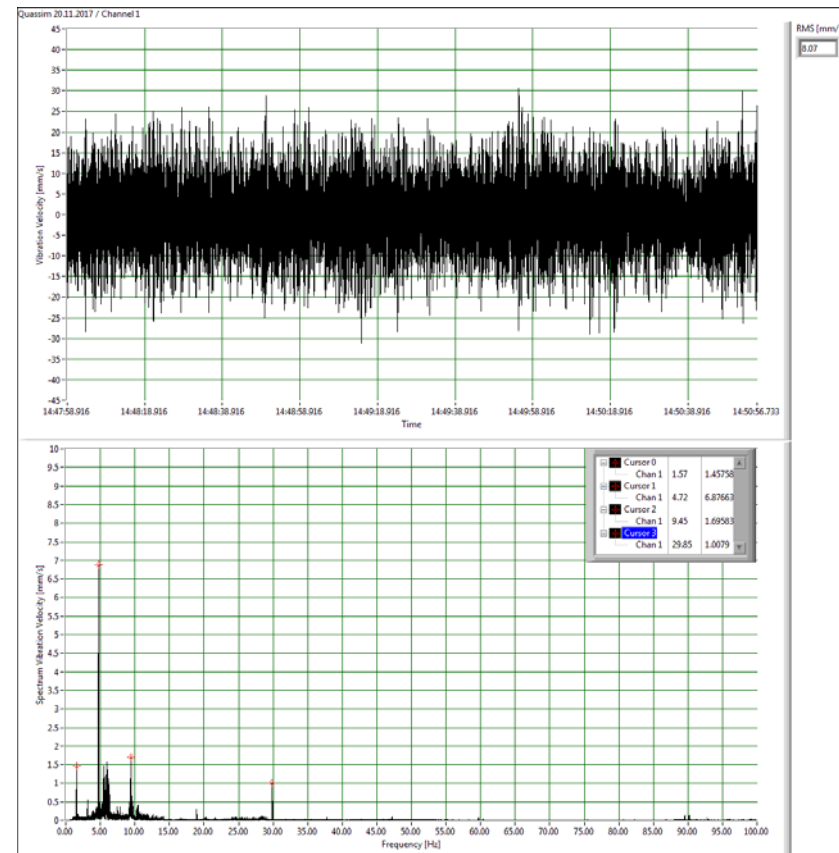



# Presentation outline

## Instrumentation

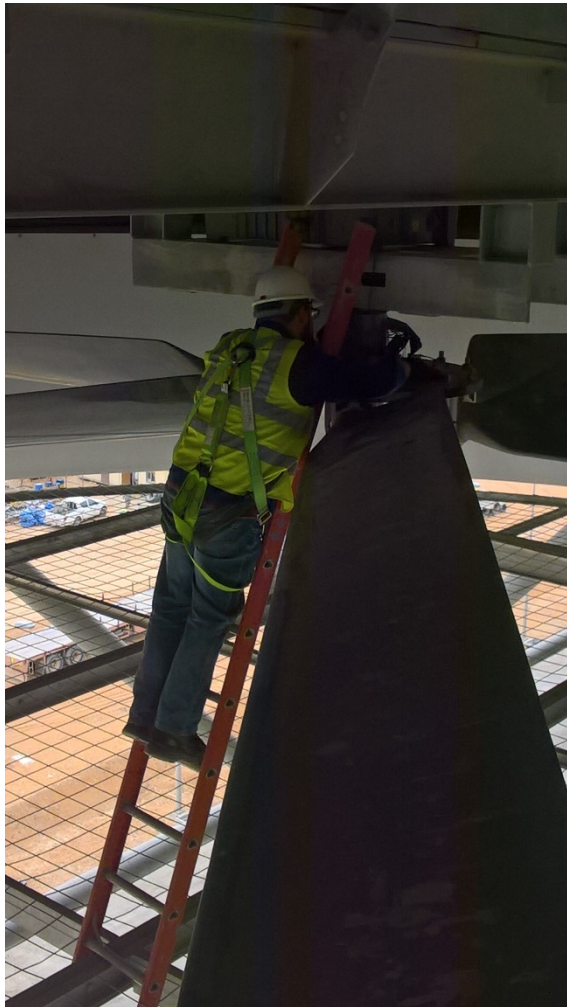

## Measurements

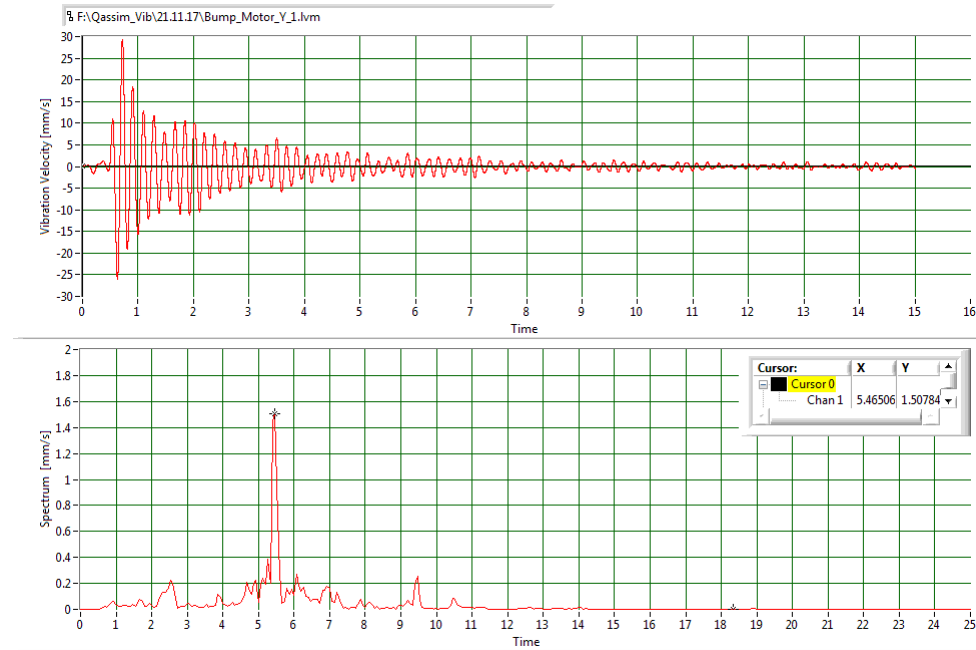

## Recommendations





# Wind speed and direction measurement

Three-axis ultrasonic anemometer installed on the corner of Block B to measure wind speed and direction.





# Wind speed and direction measurement

Test fan on the corner of Block A subjected to dominant winds.

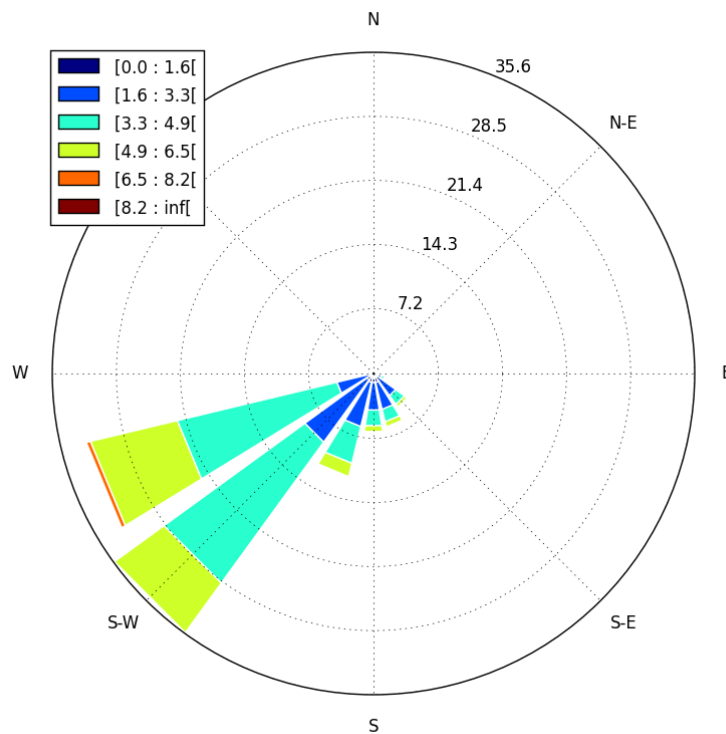

20 Nov 2017

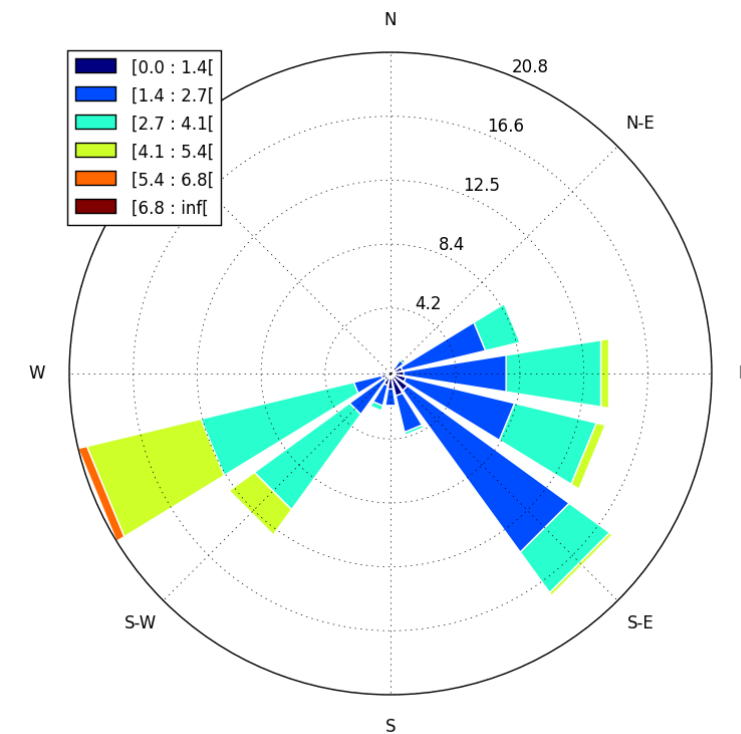

21 Nov 2017



# Vibration sensors

Vibration sensors attached to gearbox and motor NDE to measure acceleration in  $x$ - and  $y$ -direction.

Sensors at motor NDE expected to provide highest level of rigid body vibration.

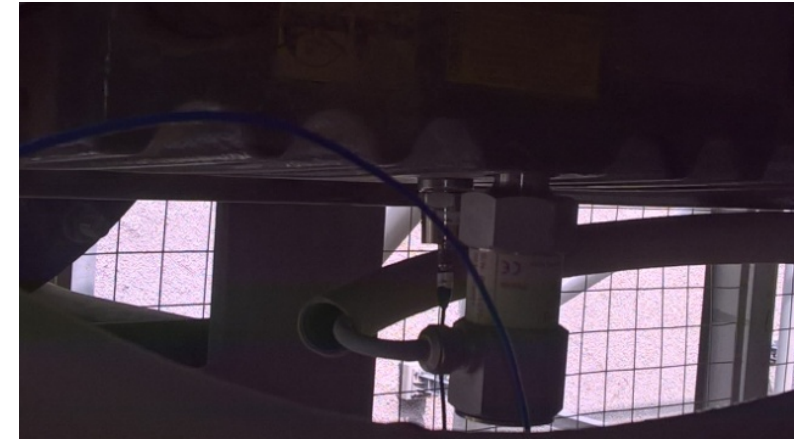



# Strain gauges

Strain gauges attached to fan blade and shaft.

Position sensor used to determine fan position.

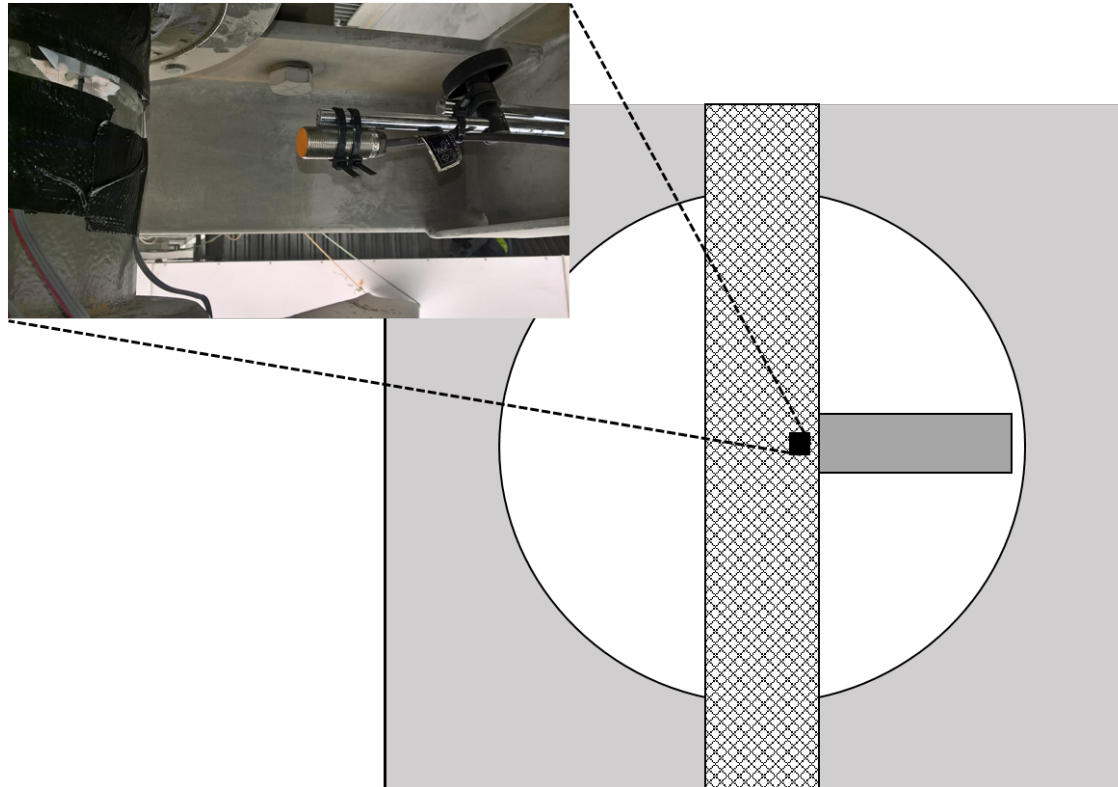

Bump test in  $y$ -direction:

Natural frequency of 5.46 Hz

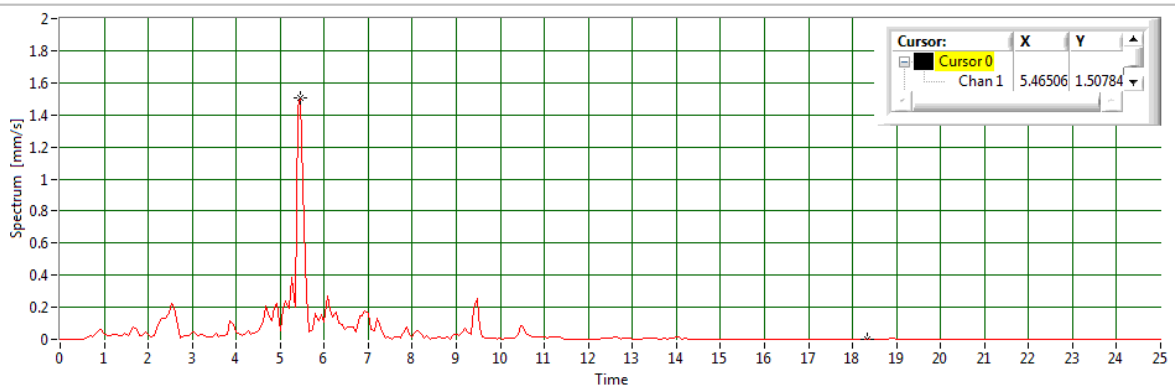
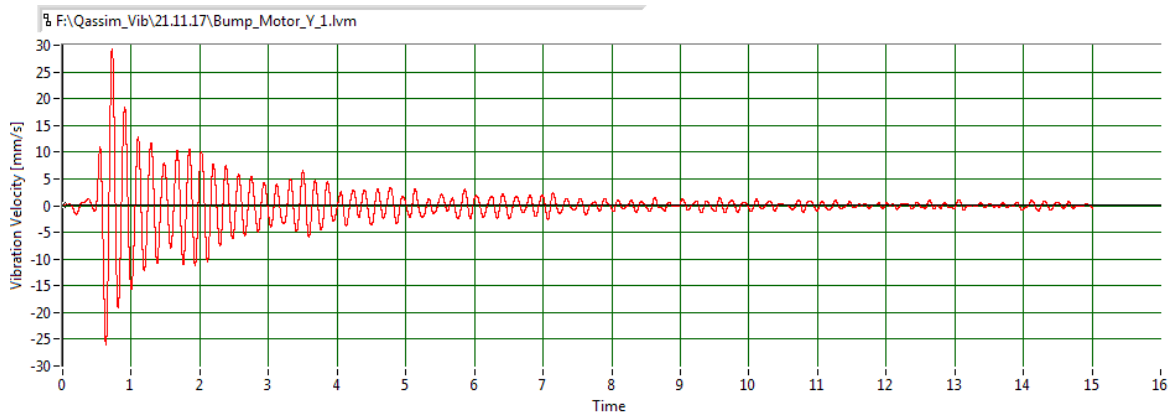

Bump test in  $x$ -direction:

Natural frequencies of 10.33 Hz and 12.5 Hz

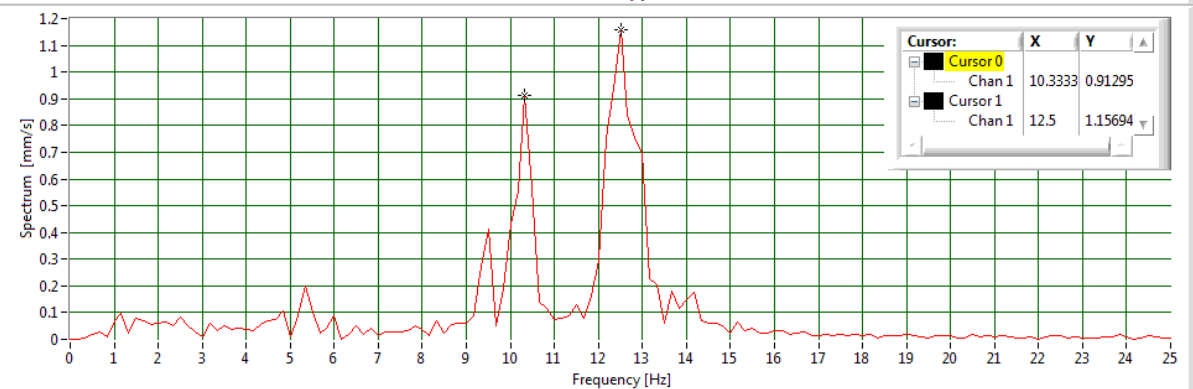
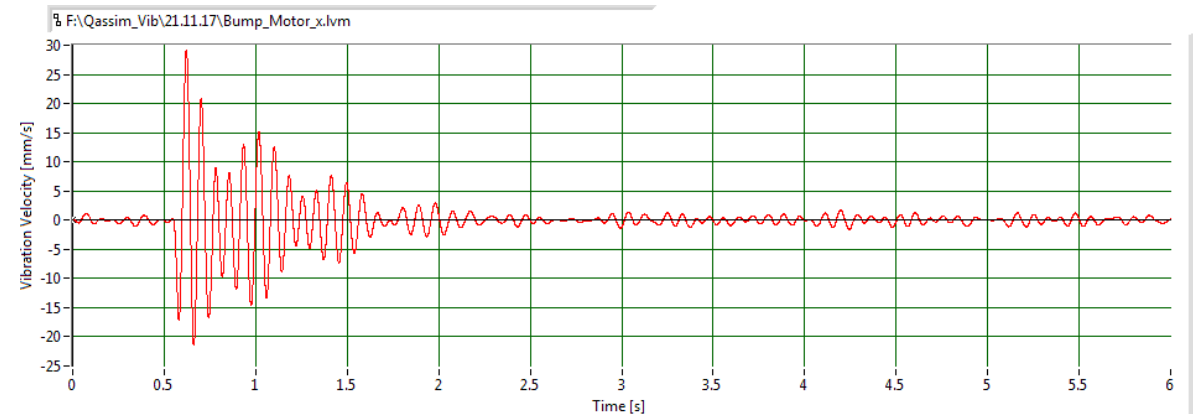





# Measurements – gearbox total vibration levels

y-direction: RMS: 2.8 mm/s

x-direction: RMS: 1.4 mm/s

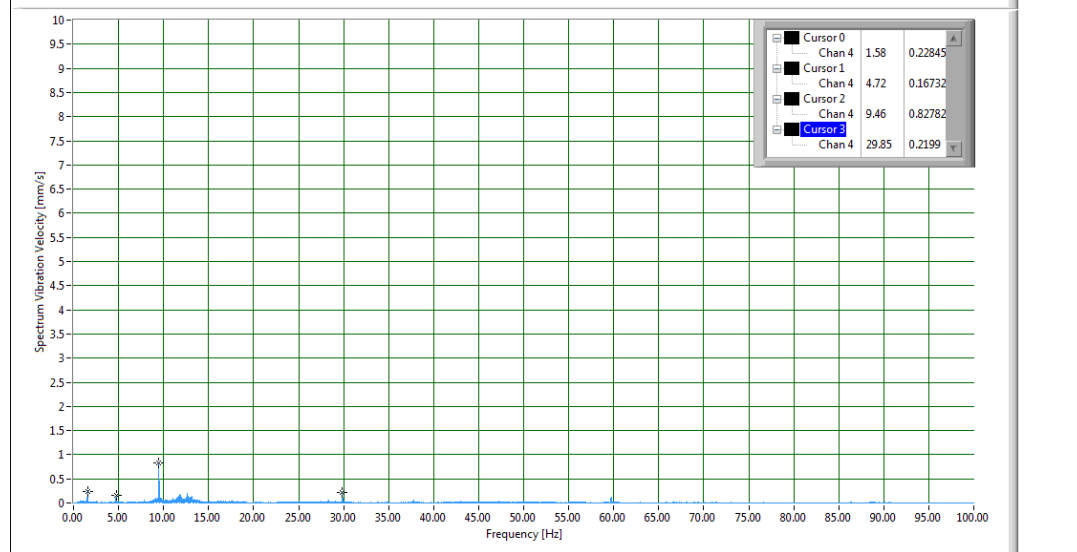
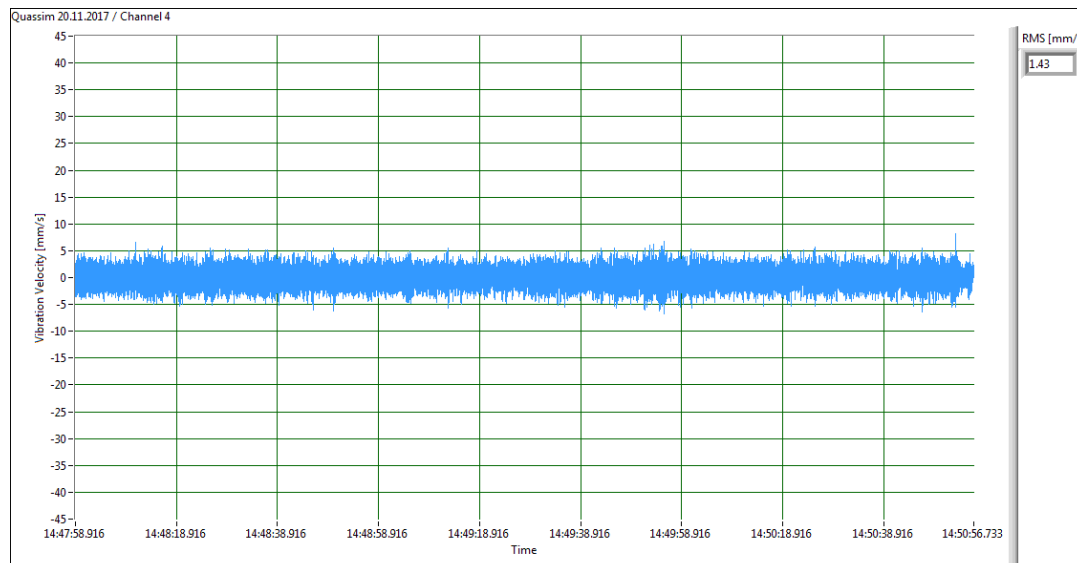
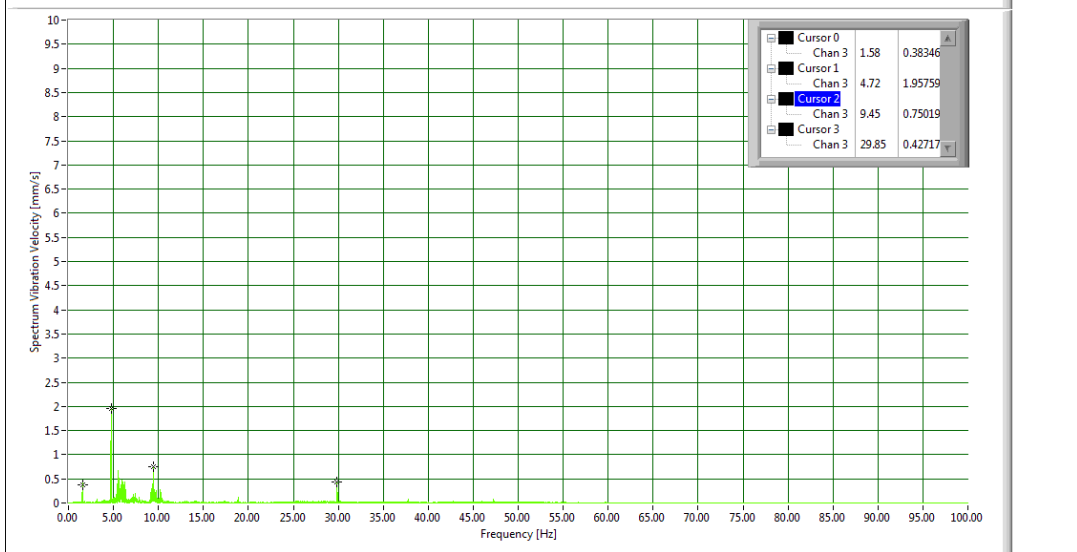
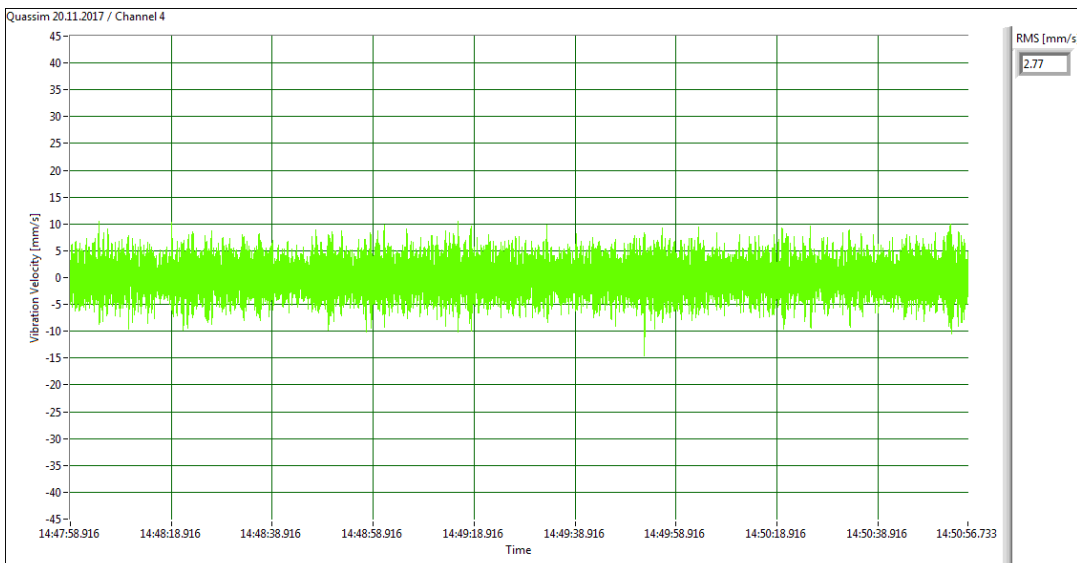



# Measurements – motor NDE total vibration levels

y-direction: RMS: 8.1 mm/s

x-direction: RMS: 9.4 mm/s

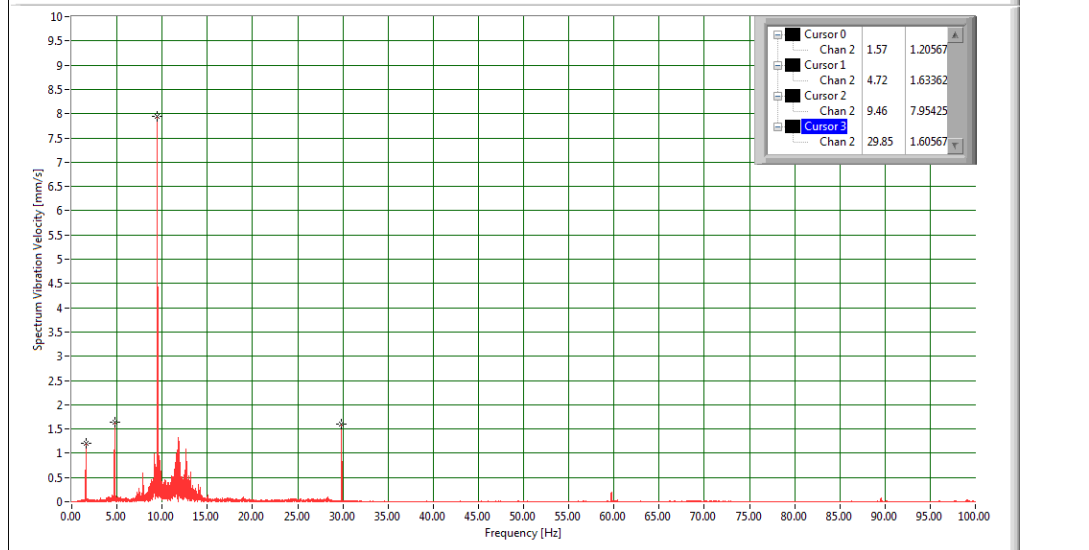
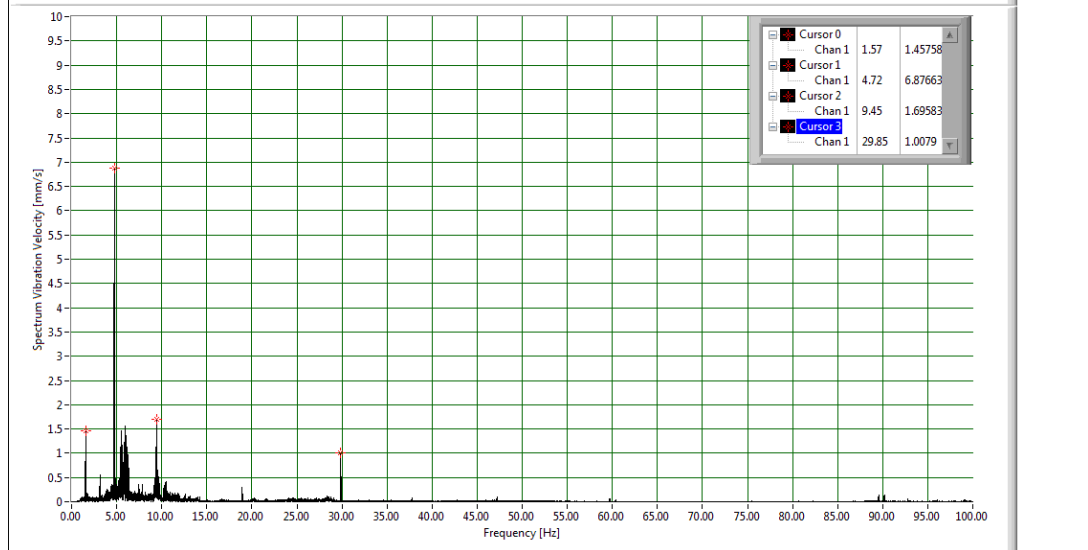
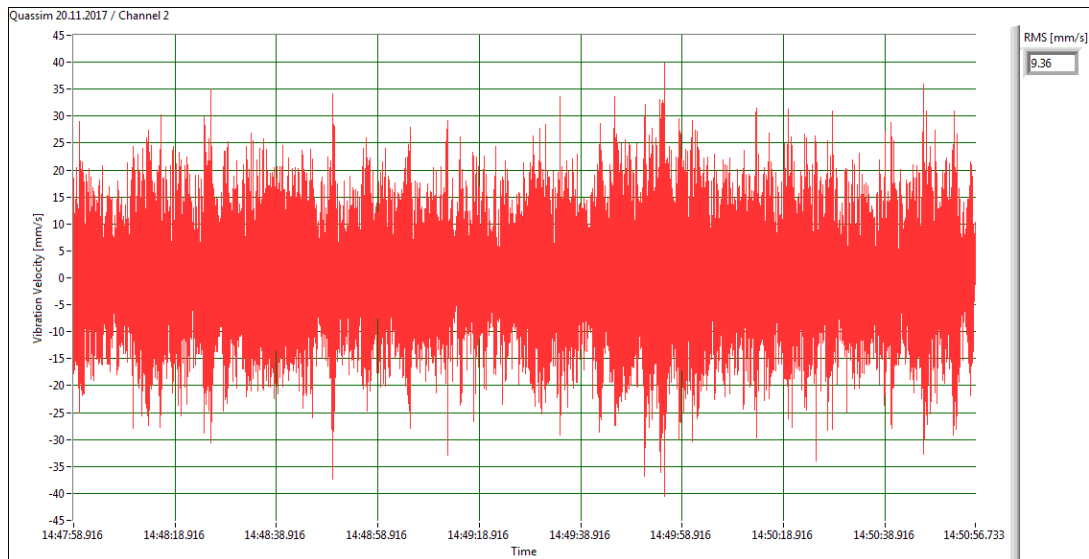
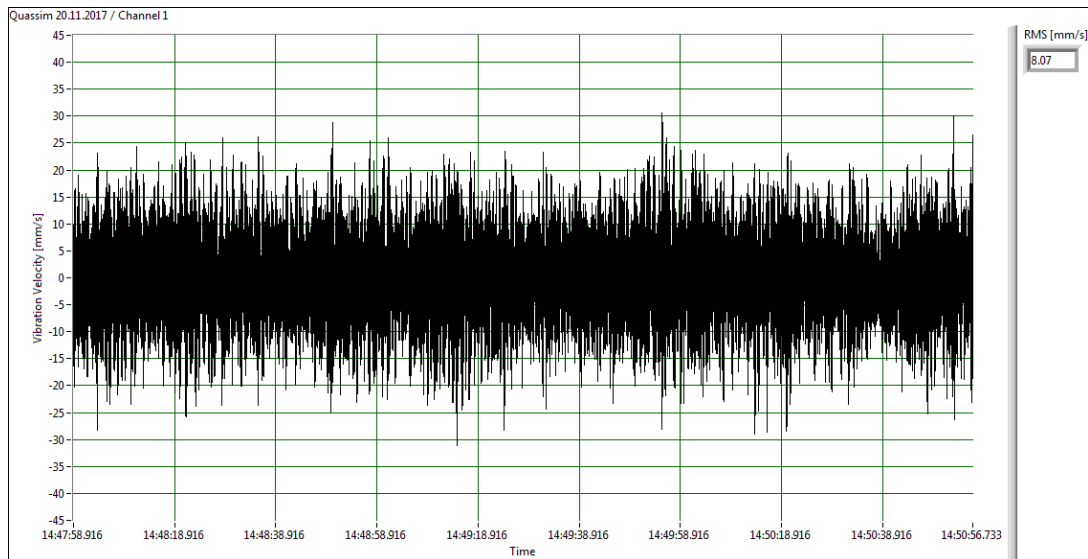



# Measurements – the effect of wind on motor NDE vibration

Instantaneous  
vibration velocity

RMS calculated  
over 2 seconds

Instantaneous  
wind speed

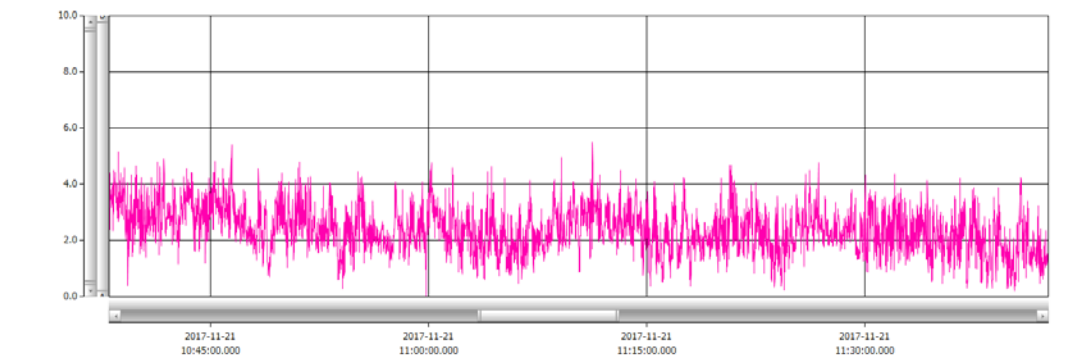
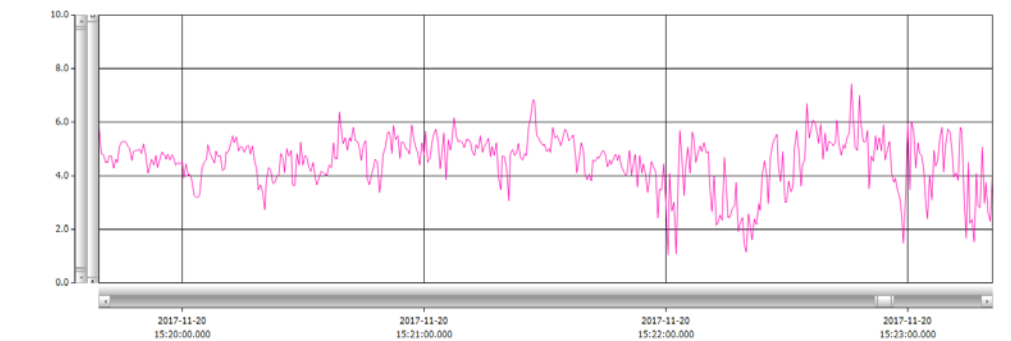
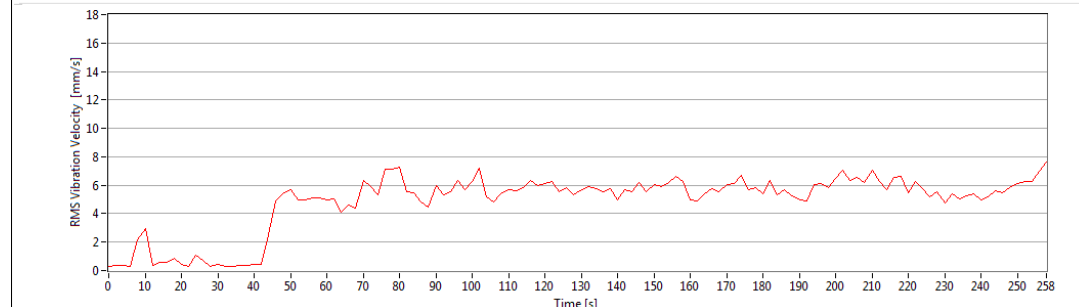
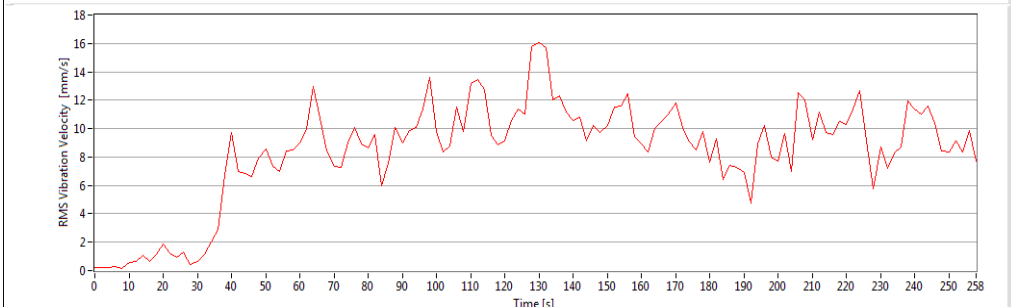
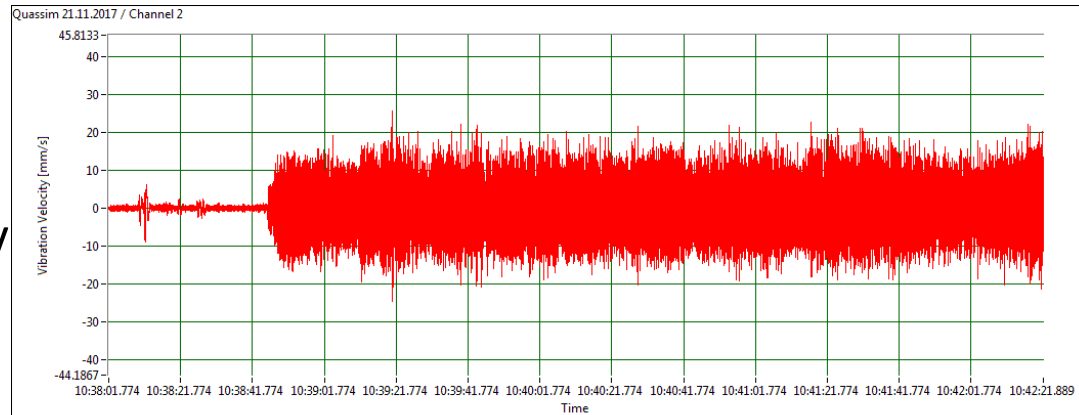
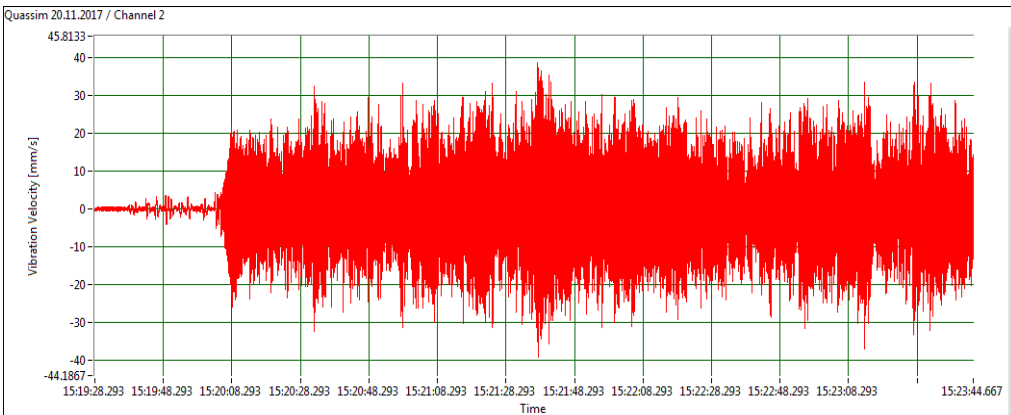



# Measurements – the effect of wind

Blade loading increases with increasing wind speed.

Blade loading between 15:27 and 15:32 was high enough to exceed set measurement range.

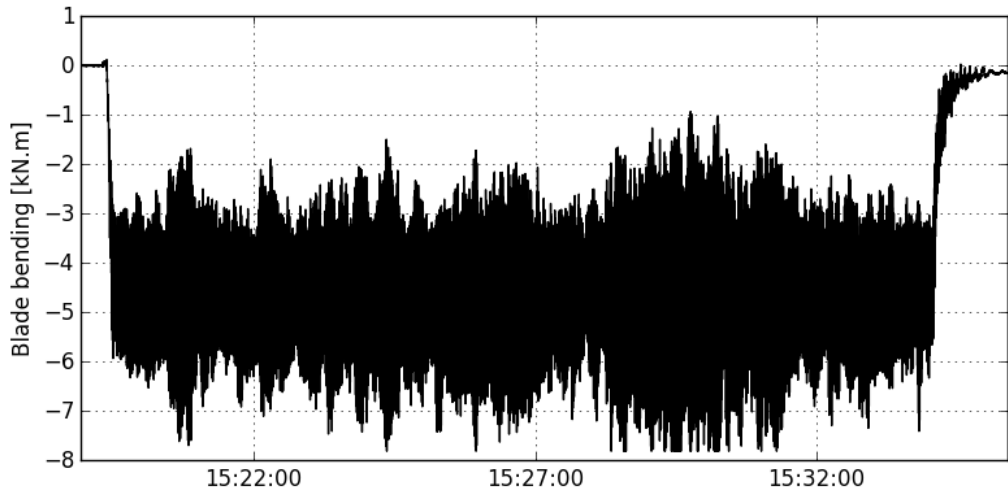
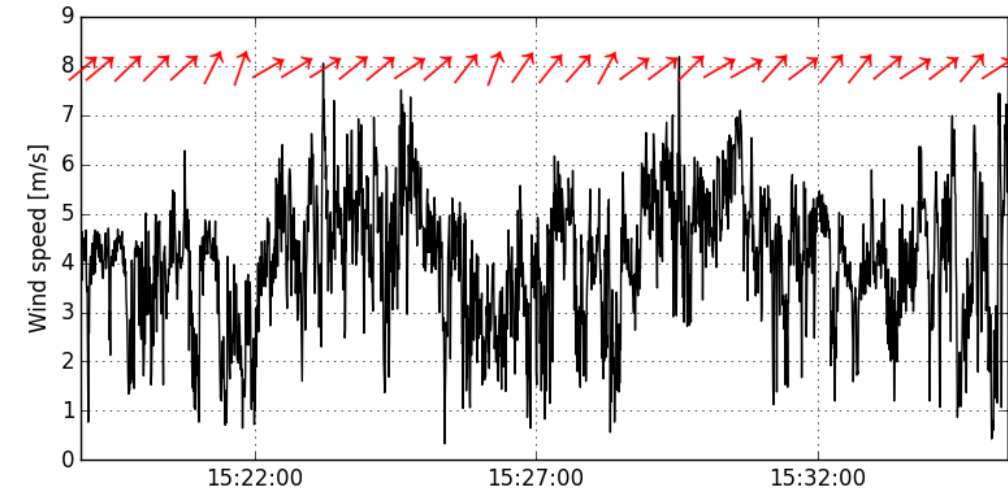

Maximum blade loading occurs at the windward side of the fan.

Dominant peaks at 1x, 2x and 4x rotational speed.

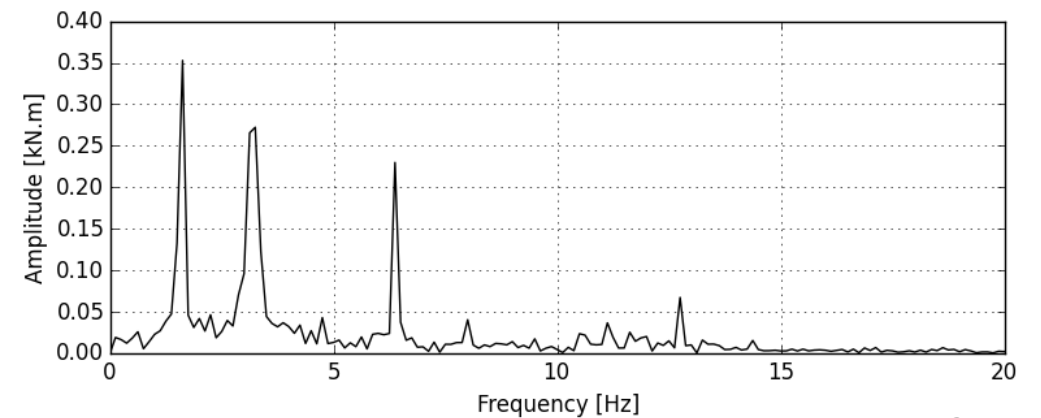
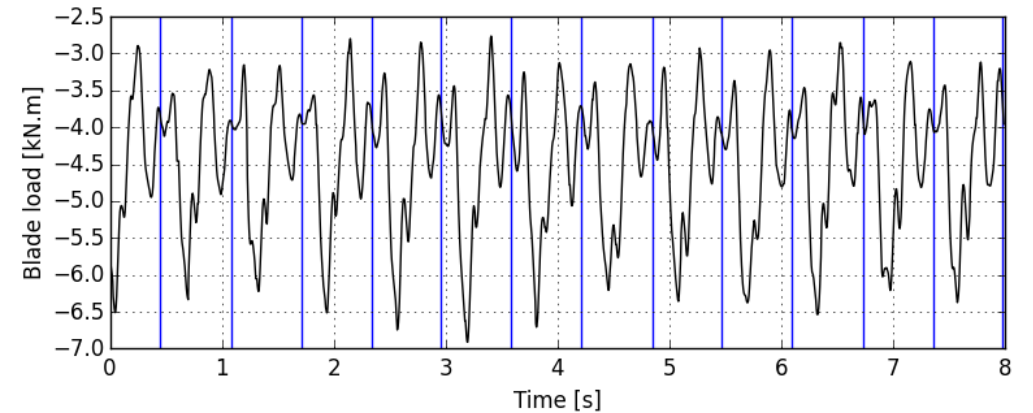

1. Transient wind effects, such as gusts, increases blade loading and vibration
2. RMS vibration values at the NDE of the motor, calculated over 2 seconds, exceeds the limits stipulated in ISO 10816-3:

<b>Support class</b>	<b>Zone boundary</b>	<b>RMS displacement [<math>\mu\text{m}</math>]</b>	<b>RMS velocity [mm/s]</b>
Rigid	A/B	22	1.4
	B/C	45	2.8
	C/D	71	4.5
Flexible	A/B	37	2.3
	B/C	71	4.5
	C/D	113	7.1

## ISO 10816-3:

“However, the vibration criteria presented in this part of ISO 10816 are generally only applicable to fans with power ratings greater than 300 kW or fans which are not flexibly supported... classifications can be agreed between the manufacturer and the customer, using results of previous operational experience, see also ISO 14694.”

## ISO 14694:

“This international Standard gives specifications and balance limits of fans for all applications except those designed solely for air circulation, for example, ceiling fans and table fans. However, it is limited to fans of all types installed with a power of less than 300 kW or to a commercially available standard electric motor with a maximum power of 355 kW (following the R20 series). For fans of greater power than this, the applicable limits are those given in ISO 10816-3.”

Condition	Rigidly mounted		Flexibly mounted	
	Peak [mm/s]	RMS [mm/s]	Peak [mm/s]	RMS [mm/s]
<b>Start – Up</b>	6.4	4.5	8.8	6.3
<b>Alarm</b>	10.2	7.1	16.5	11.8
<b>Shutdown</b>	12.7	9.0	17.8	12.5



# Recommendations – averaging time vs. time delay

Increasing the averaging time from 2 seconds to 256 seconds reduces the RMS vibration level.

Averaging times are not stipulated in ISO 14694 or ISO 14695. However, VDI 3834 (for wind turbines) states that:

“For the aerodynamically excited vibration of the nacelles, towers and components with frequencies between 0,1 Hz and 10 Hz and relatively high accelerations and velocities, the evaluation period should be set at 10 min.”

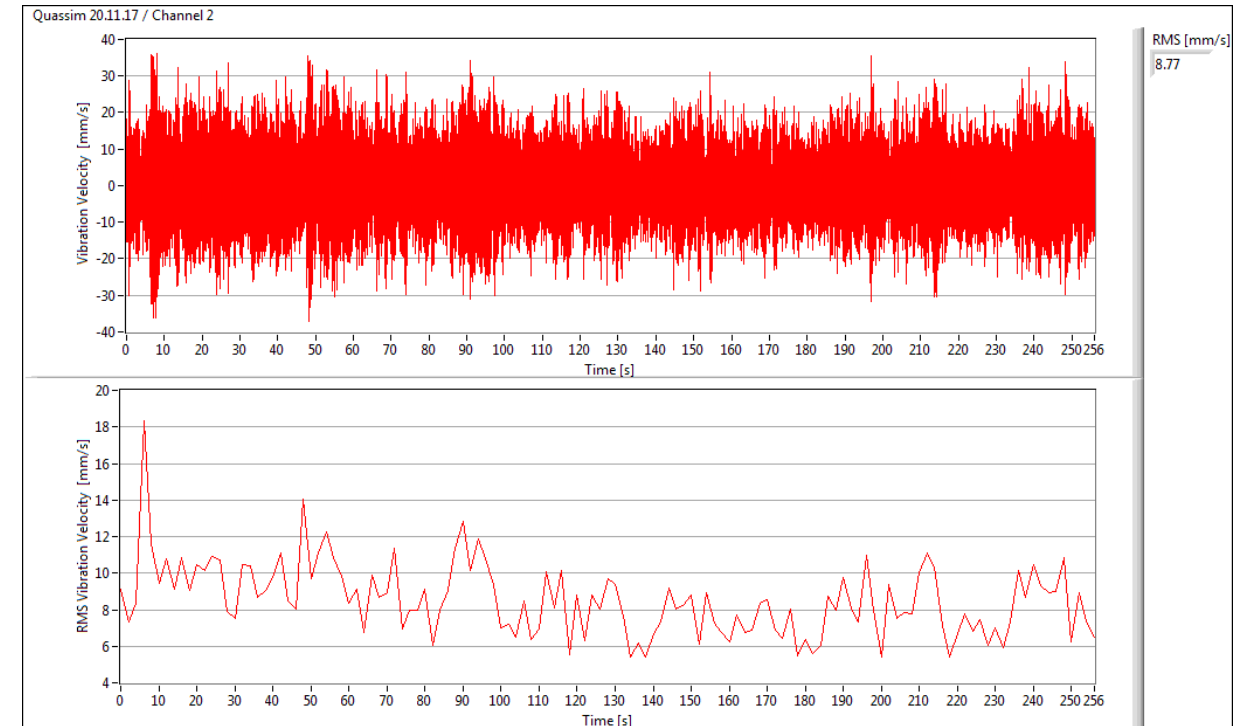
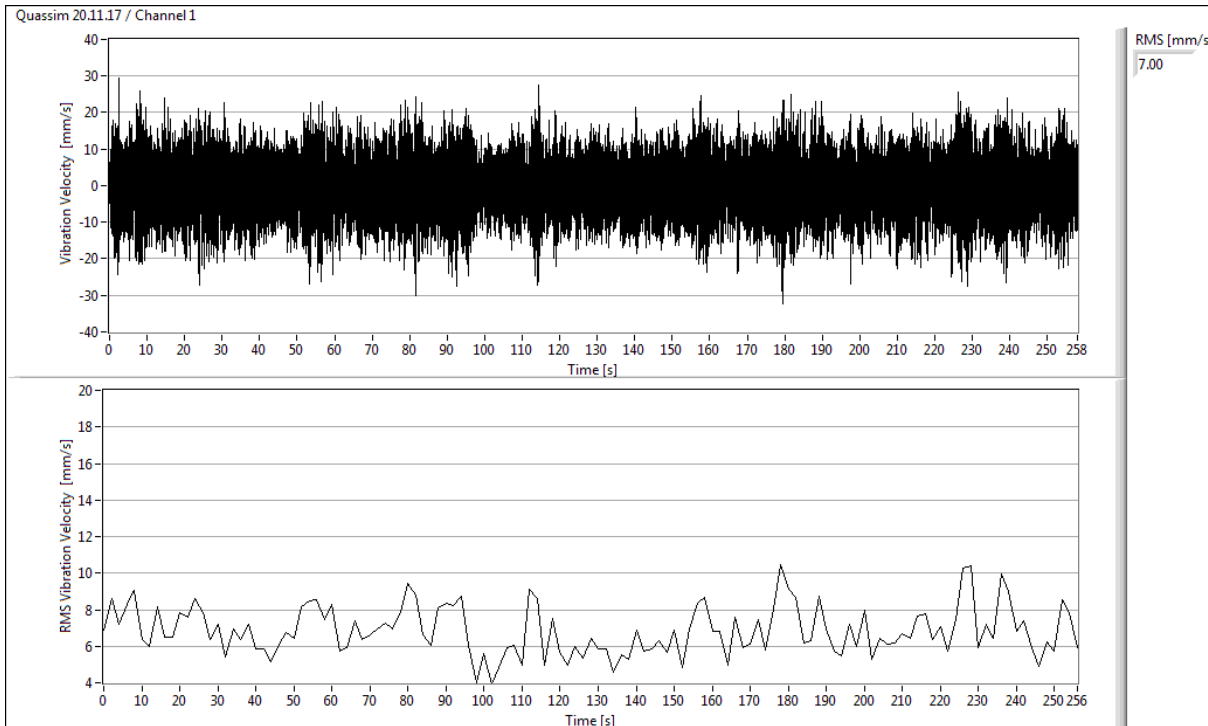



# Recommendations – frequency analysis

Chapter 5 of the IEC 60721-3-3 standard “Classification of environmental conditions” provides vibration limits for electrical motors (typically class 3M3 for ACC motors as specified by the motor manufacturer).

**Table 6 – Classification of mechanical conditions**

Environmental parameter	Unit	Class							
		3M1	3M2	3M3	3M4	3M5	3M6	3M7	3M8
a) <i>Stationary vibration, sinusoidal:</i> displacement amplitude acceleration amplitude frequency range	mm	0,3	1,5	1,5	3,0	3,0	7,0	10	15
	m/s <sup>2</sup>	1	5	5	10	10	20	30	50
	Hz	2-9 9-200	2-9 9-200	2-9 9-200	2-9 9-200	2-9 9-200	2-9 9-200	2-9 9-200	2-9 9-200
b) <i>Non-stationary vibration including shock:</i> (see figure 1) shock response spectrum type L, peak acceleration $\hat{a}$ shock response spectrum type I, peak acceleration $\hat{a}$ shock response spectrum type II, peak acceleration $\hat{a}$	m/s <sup>2</sup>	40	40	70	None	None	None	None	None
	m/s <sup>2</sup>	None	None	None	100	None	None	None	None
	m/s <sup>2</sup>	None	None	None	None	250	250	250	250
	m/s <sup>2</sup>	None	None	None	None	250	250	250	250





# Recommendations – frequency analysis

$$x(t) = A \sin \omega t$$

$$\dot{x}(t) = \omega A \cos \omega t$$

$$\ddot{x}(t) = \omega^2 A \sin \omega t$$

$$\log \dot{x} = \log x + \log \omega$$

$$\log \dot{x} = \log \ddot{x} - \log \omega$$

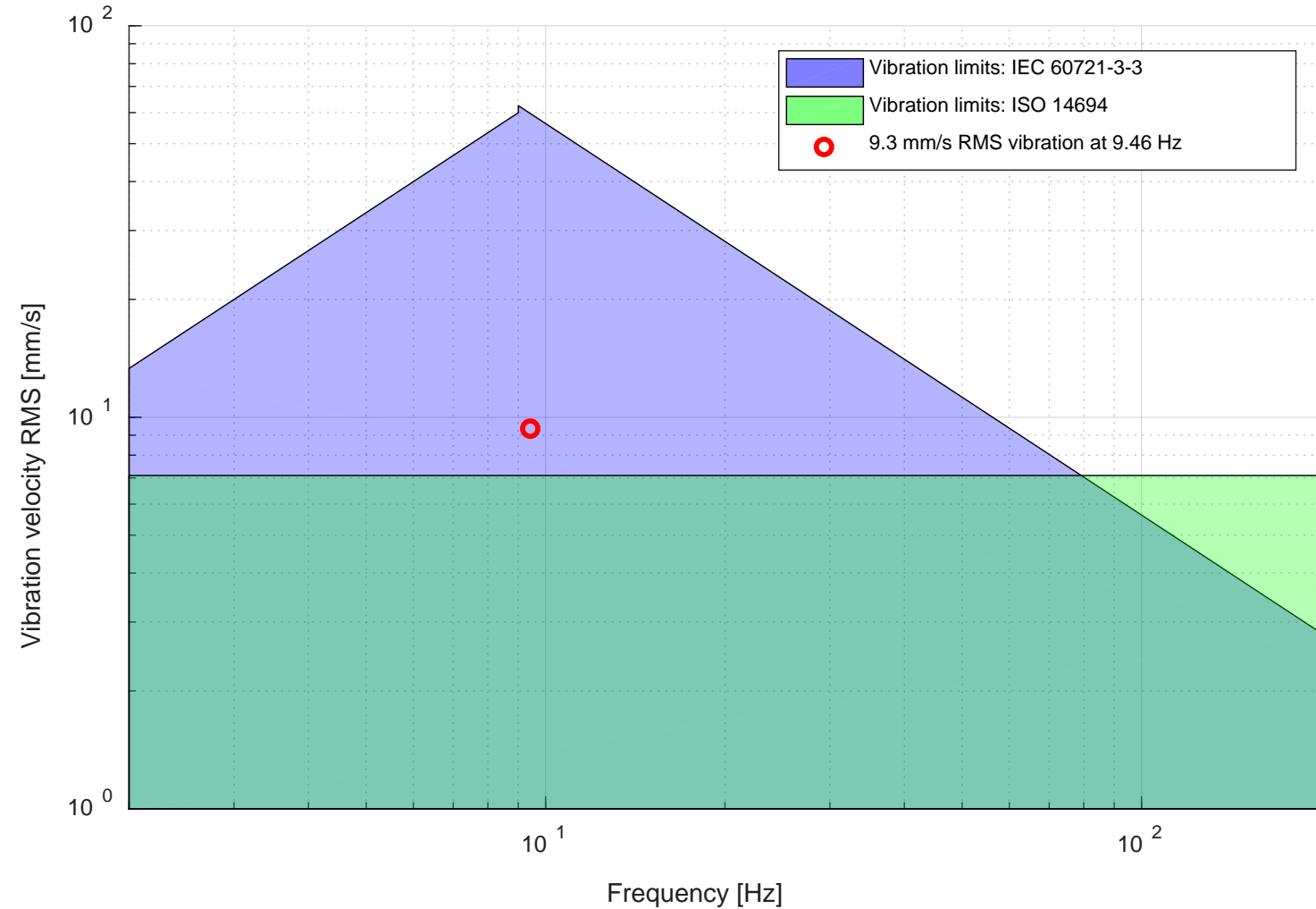

The immediate recommendations according to the findings are:

1. Use the limits from the correct standard
2. Increase the time delay on the transmitter to at least 20 s

Further recommendations for discussion:

1. Increasing the averaging time when calculating the RMS value. Increasing the time delay will reduce the number of trips, but not the RMS values.
2. Differentiating between structural vibration and vibrations generated by the fan drive itself
3. Introduction of a component and frequency dependence of the vibration limits. Perhaps use the VDI 3834 as an example for how to determine vibration limits?

Thank you for your attention



*saam vorentoe · masiye phambili · forward together*

